

Please check the examination details below before entering your candidate information

Candidate surname

Other names

Centre Number

Candidate Number

--	--	--	--	--

--	--	--	--	--

**Pearson Edexcel Level 1/Level 2 GCSE (9–1)**

**Monday 10 June 2024**

Morning (Time: 1 hour 30 minutes)

Paper  
reference

**1MA1/3F**

**Mathematics**  
**PAPER 3 (Calculator)**  
**Foundation Tier**



**You must have:** Ruler graduated in centimetres and millimetres, protractor, pair of compasses, pen, HB or B pencil, eraser, calculator, Formulae Sheet (enclosed). Tracing paper may be used.

Total Marks

## Instructions

- Use **black** ink or ball-point pen.
- If pencil is used for diagrams/sketches/graphs it must be dark (HB or B).
- **Fill in the boxes** at the top of this page with your name, centre number and candidate number.
- Answer **all** questions.
- Answer the questions in the spaces provided  
– *there may be more space than you need.*
- You must **show all your working**.
- Diagrams are **NOT** accurately drawn, unless otherwise indicated.
- **Calculators may be used.**
- If your calculator does not have a  $\pi$  button, take the value of  $\pi$  to be 3.142 unless the question instructs otherwise.

## Information

- The total mark for this paper is 80
- The marks for **each** question are shown in brackets  
– *use this as a guide as to how much time to spend on each question.*

## Advice

- Read each question carefully before you start to answer it.
- Try to answer every question.
- Check your answers if you have time at the end.

Turn over ►

P76926A

©2024 Pearson Education Ltd.  
F:1/1/1/



P 7 6 9 2 6 A 0 1 2 8



Pearson

Answer ALL questions.

Write your answers in the spaces provided.

You must write down all the stages in your working.

1 Write 23% as a fraction.

.....

(Total for Question 1 is 1 mark)

2 Change 800 centimetres to metres.

..... metres

(Total for Question 2 is 1 mark)

3 Write down the value of the 3 in the number 62837

.....

(Total for Question 3 is 1 mark)

4 Simplify  $7a + a - 5a$

.....

(Total for Question 4 is 1 mark)

5 Write the following fractions in order of size.  
Start with the smallest fraction.

$$\frac{1}{2} \quad \frac{2}{3} \quad \frac{1}{4}$$

.....

(Total for Question 5 is 1 mark)

DO NOT WRITE IN THIS AREA

DO NOT WRITE IN THIS AREA

DO NOT WRITE IN THIS AREA



DO NOT WRITE IN THIS AREA

DO NOT WRITE IN THIS AREA

DO NOT WRITE IN THIS AREA

6 A map has a scale of 1 cm represents 4 km.

On the map, the distance from town A to town B is 8 cm.

(a) Work out the real distance, in km, from town A to town B.

..... km  
(2)

The real length of a road is 10 km.

(b) Work out the length of the road on the map.  
Give the units of your answer.

.....  
(2)

**(Total for Question 6 is 4 marks)**



P 7 6 9 2 6 A 0 3 2 8

- 7 Julie asks some students how they travel to school.  
The chart shows her results.

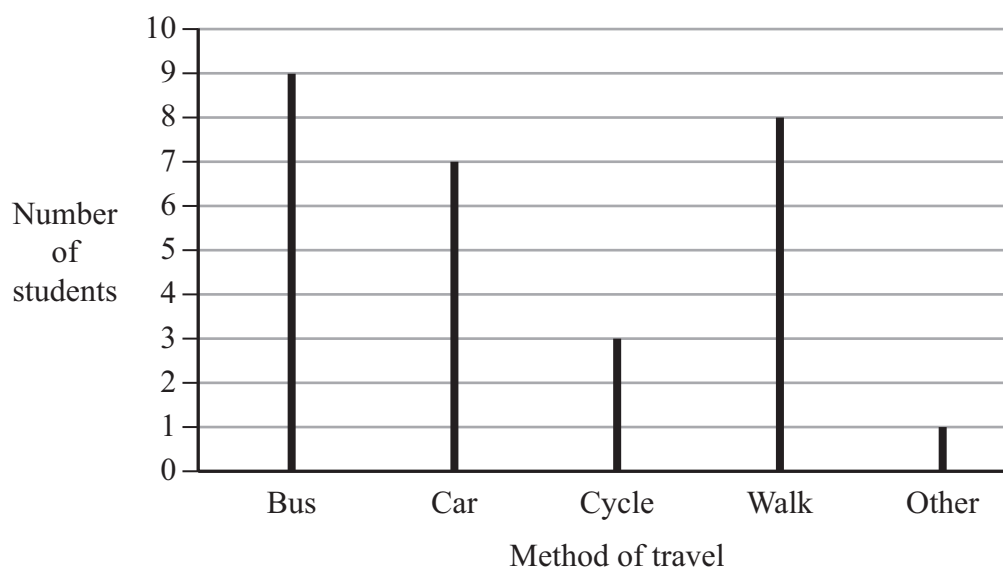

- (a) Write down which method of travel is the mode.

.....  
(1)

More students walk to school than cycle to school.

- (b) How many more?

.....  
(1)

**(Total for Question 7 is 2 marks)**



DO NOT WRITE IN THIS AREA

DO NOT WRITE IN THIS AREA

DO NOT WRITE IN THIS AREA

8 Aisha was born in 1993

There was an election in the year of Aisha's 18th birthday.

There is an election every 5 years.

Will there be an election in 2030?

You must show how you get your answer.

---

(Total for Question 8 is 3 marks)



9 Lucia is going on a skiing holiday.

The cost of ski hire is £26 per day.

The cost of a lift pass is £45 per day.

The cost of ski lessons is £23.50 per hour.

Lucia will pay for

ski hire for 5 days

a lift pass for 4 days

ski lessons for 8 hours.

Lucia has £500

Show that Lucia has enough money to pay for the total cost of ski hire, the lift pass and the ski lessons.

(Total for Question 9 is 3 marks)

DO NOT WRITE IN THIS AREA

DO NOT WRITE IN THIS AREA

DO NOT WRITE IN THIS AREA



DO NOT WRITE IN THIS AREA

DO NOT WRITE IN THIS AREA

DO NOT WRITE IN THIS AREA

10 Here is a circle.

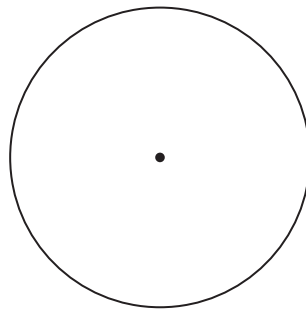

(a) On the diagram above, draw a radius of the circle.

(1)

Here is another circle.

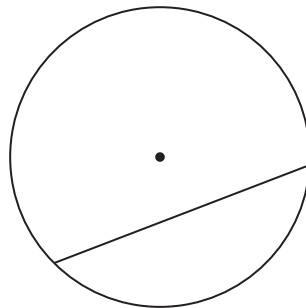

(b) Write down the mathematical name for the straight line inside this circle.

.....  
(1)

**(Total for Question 10 is 2 marks)**



DO NOT WRITE IN THIS AREA

- 11 There are 8 episodes in a TV series.  
Each episode lasts 45 minutes.

Work out the total time that the 8 episodes last.  
Give your answer in hours.

..... hours

**(Total for Question 11 is 2 marks)**

- 12 Write down three prime numbers that are between 20 and 40

..... , ..... , .....

**(Total for Question 12 is 2 marks)**

DO NOT WRITE IN THIS AREA

DO NOT WRITE IN THIS AREA





DO NOT WRITE IN THIS AREA

DO NOT WRITE IN THIS AREA

DO NOT WRITE IN THIS AREA

13 James asks students in Year 10 and Year 11 to name their favourite language from French or German or Spanish.

The two-way table shows information about his results.

	French	German	Spanish	Total
Year 10	33		34	
Year 11		45		113
Total			67	207

Complete the two-way table.

(Total for Question 13 is 3 marks)



14 The table gives information about the drinks people ordered in a cafe.

Drink	Number of people
Coffee	30
Hot chocolate	10
Tea	50

Draw an accurate pie chart for this information.

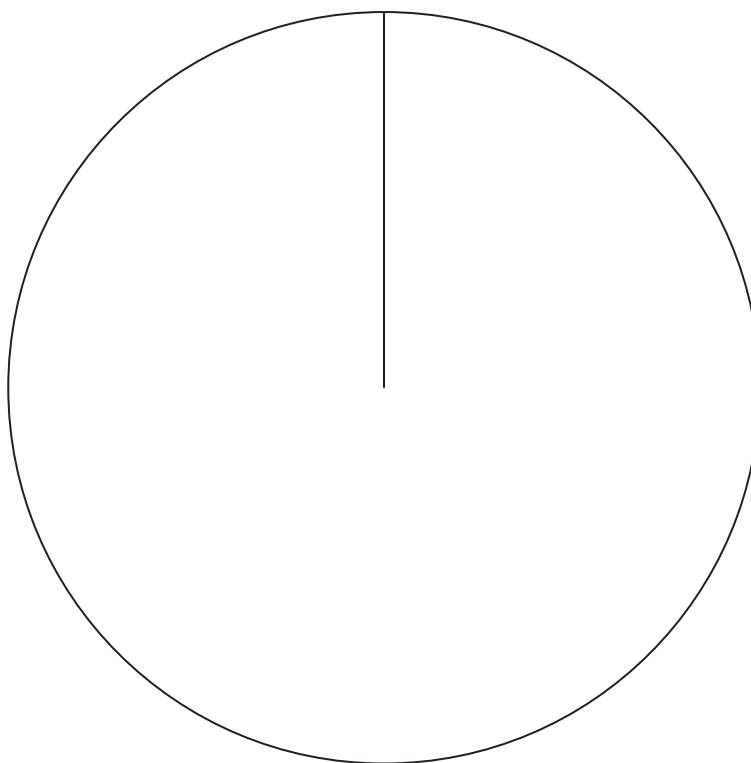

(Total for Question 14 is 3 marks)

DO NOT WRITE IN THIS AREA

DO NOT WRITE IN THIS AREA

DO NOT WRITE IN THIS AREA



DO NOT WRITE IN THIS AREA

15 Which is greater

15% of 88 **or** 20% of 62?

You must show all your working.

(Total for Question 15 is 3 marks)



16 (a) Simplify  $m \times m \times m \times m$

.....  
(1)

In a competition, a player gets

5 points for each game they win  
2 points for each game they draw  
0 points for each game they lose.

Amy wins  $x$  games and draws  $y$  games.

(b) Write down an expression, in terms of  $x$  and  $y$ , for the total number of points Amy gets.

.....  
(2)

**(Total for Question 16 is 3 marks)**

DO NOT WRITE IN THIS AREA

DO NOT WRITE IN THIS AREA

DO NOT WRITE IN THIS AREA



DO NOT WRITE IN THIS AREA

DO NOT WRITE IN THIS AREA

DO NOT WRITE IN THIS AREA

17 Here are the ingredients needed to make 20 shortbread biscuits.

**Ingredients for 20 shortbread biscuits**

120 g of butter  
200 g of flour  
50 g of sugar

Heidi wants to make 30 shortbread biscuits.

How much of each ingredient will Heidi need?

butter ..... g  
flour ..... g  
sugar ..... g

**(Total for Question 17 is 3 marks)**



P 7 6 9 2 6 A 0 1 3 2 8

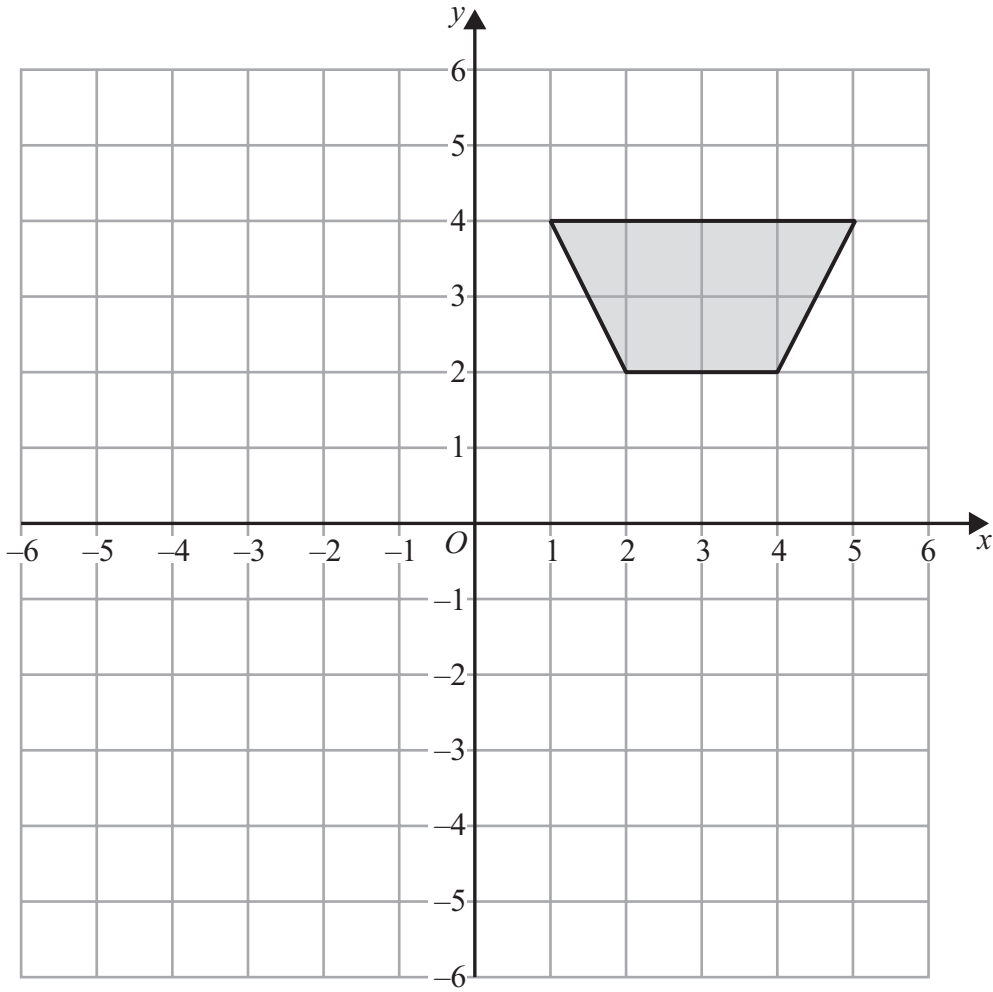

(a) On the grid above, rotate the shaded shape  $180^\circ$  about  $(0, 0)$

(2)

DO NOT WRITE IN THIS AREA

DO NOT WRITE IN THIS AREA

DO NOT WRITE IN THIS AREA



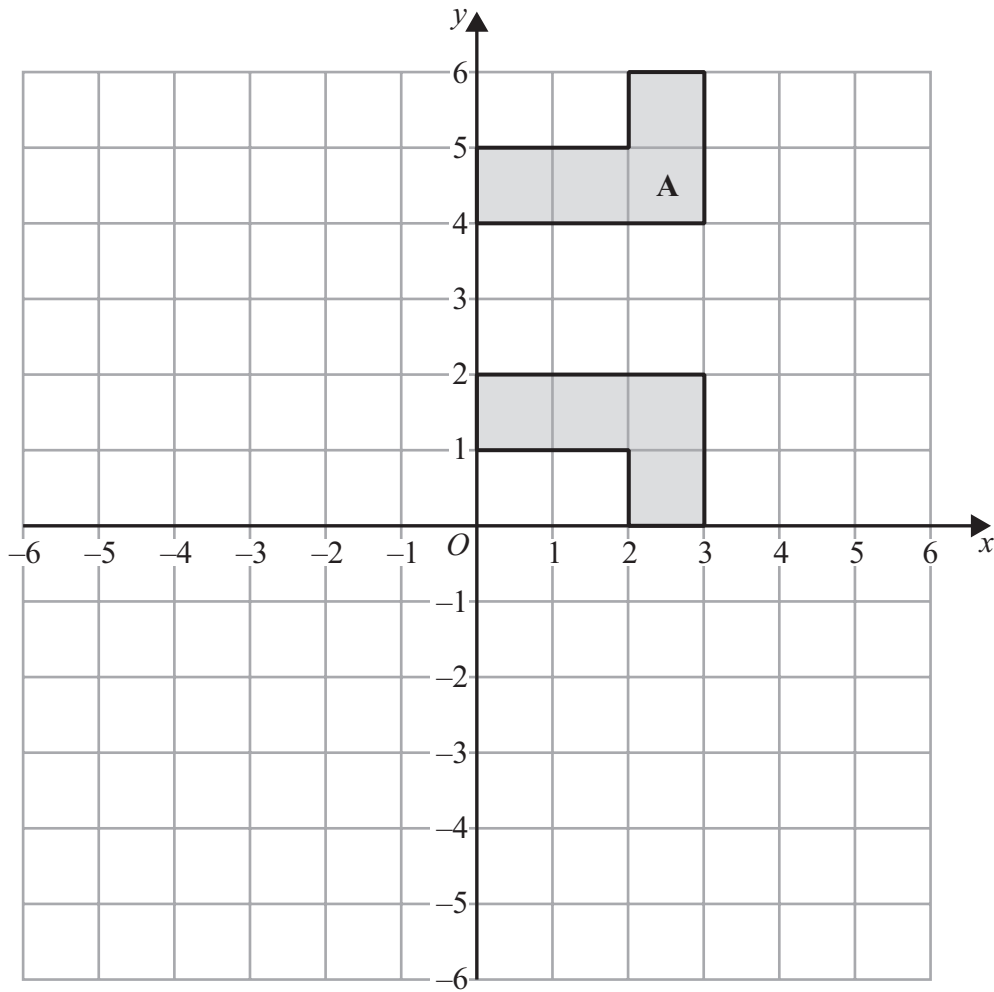

Mike was asked to

‘Reflect shape **A** in the line with equation  $x = 3$ ’

Mike’s answer is shown on the grid.  
His answer is wrong.

(b) Explain why.

(1)

(Total for Question 18 is 3 marks)



19 On the grid below, draw the graph of  $y = 3x - 2$  for values of  $x$  from  $-2$  to  $3$

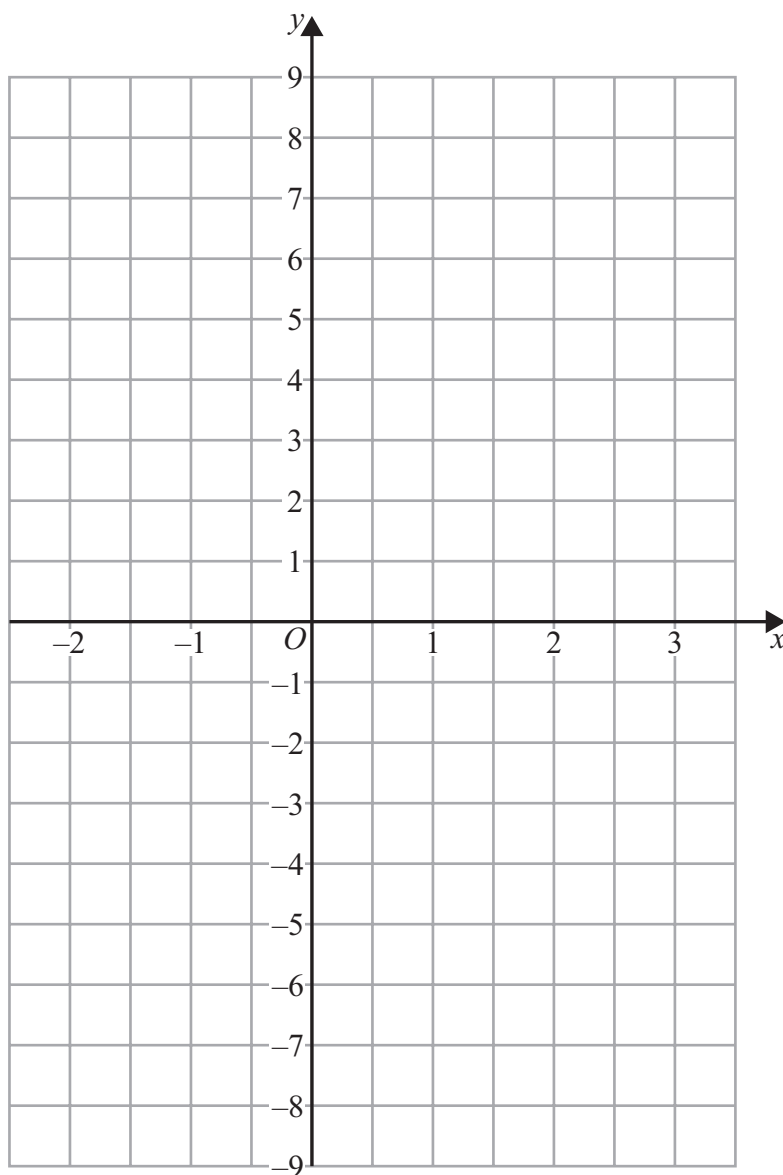

(Total for Question 19 is 3 marks)

DO NOT WRITE IN THIS AREA

DO NOT WRITE IN THIS AREA

DO NOT WRITE IN THIS AREA





DO NOT WRITE IN THIS AREA

DO NOT WRITE IN THIS AREA

DO NOT WRITE IN THIS AREA

20  $ABC$  and  $BCD$  are isosceles triangles.

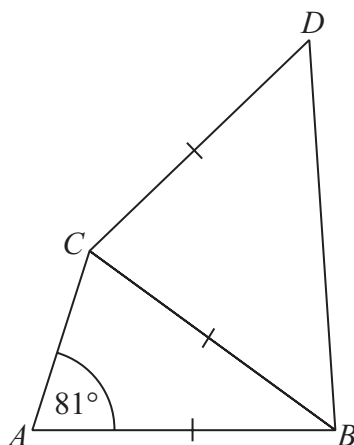

$AB = BC = CD$   
Angle  $CAB = 81^\circ$

Angle  $BCD = 4 \times$  angle  $ABC$

Find  
the size of angle  $ABC$  : the size of angle  $CBD$

Give your answer in the form  $1 : n$   
You must show all your working.

.....  
(Total for Question 20 is 5 marks)



21 (a) Factorise  $6x - 15$

.....  
(1)

(b) Factorise  $m^2 + 5m$

.....  
(1)

**(Total for Question 21 is 2 marks)**

---

22 Find the highest common factor (HCF) of 63 and 105

.....  
**(Total for Question 22 is 2 marks)**

---

DO NOT WRITE IN THIS AREA

DO NOT WRITE IN THIS AREA

DO NOT WRITE IN THIS AREA



DO NOT WRITE IN THIS AREA

DO NOT WRITE IN THIS AREA

DO NOT WRITE IN THIS AREA

23 (a) (i) Write  $5.3 \times 10^4$  as an ordinary number.

.....  
(1)

(ii) Write  $7.4 \times 10^{-5}$  as an ordinary number.

.....  
(1)

(b) Calculate the value of  $9.7 \times 10^6 + 2.45 \times 10^7$   
Give your answer in standard form.

.....  
(2)

(Total for Question 23 is 4 marks)



24 The diagram shows a solid triangular prism.

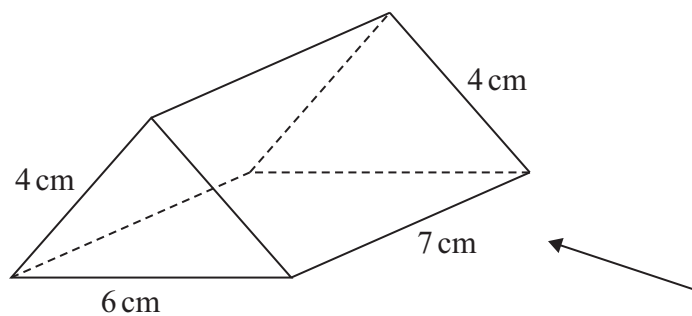

Rana is trying to draw the side elevation of the solid prism from the direction of the arrow.

Here is her answer on a centimetre grid.

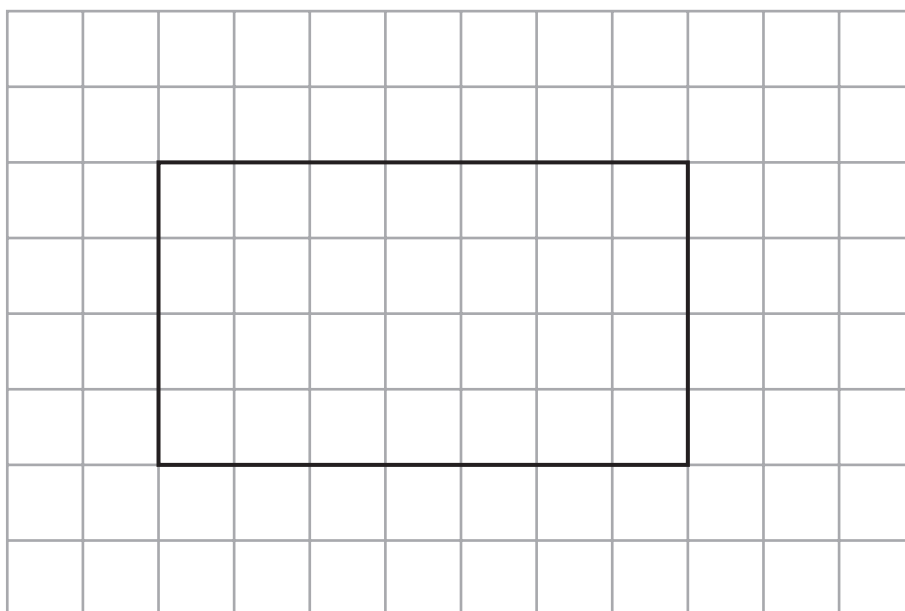

(a) Explain why Rana's side elevation is not correct.

.....

.....

.....

(1)



DO NOT WRITE IN THIS AREA

DO NOT WRITE IN THIS AREA

DO NOT WRITE IN THIS AREA

(b) On the centimetre grid below, draw a plan of the solid prism.

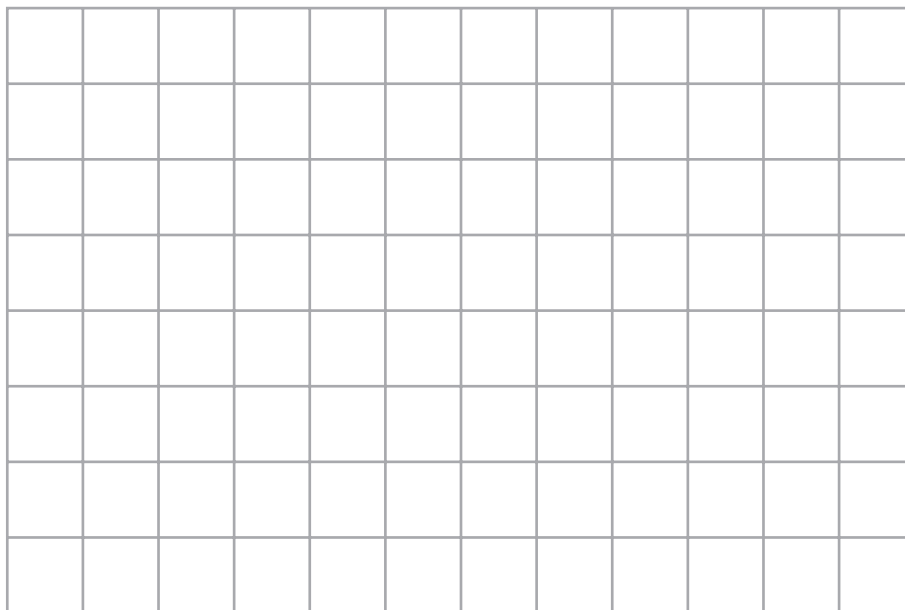

(2)

(Total for Question 24 is 3 marks)

- 25 A company has 25 000 workers.  
The number of workers increases at a rate of 6% per year for 3 years.  
Calculate the total number of workers at the end of the 3 years.

.....  
(Total for Question 25 is 4 marks)



DO NOT WRITE IN THIS AREA

DO NOT WRITE IN THIS AREA

DO NOT WRITE IN THIS AREA

26 Habib has two identical tins.

He puts 600 grams of flour into one of the tins.

The flour fills the tin completely.

The density of the flour is  $0.6 \text{ g/cm}^3$

Habib puts 600 grams of salt into the other tin.

The salt does **not** fill the tin completely.

The volume of the space in the tin that is **not** filled with salt is  $700 \text{ cm}^3$

Work out the density of the salt.

You must show all your working.

.....  $\text{g/cm}^3$

(Total for Question 26 is 4 marks)



DO NOT WRITE IN THIS AREA

27 Tim has two biased coins, coin A and coin B.  
He is going to throw both coins.

The probability that coin A will land on heads is 0.6  
The probability that coin B will land on heads is 0.55

(a) Complete the probability tree diagram.

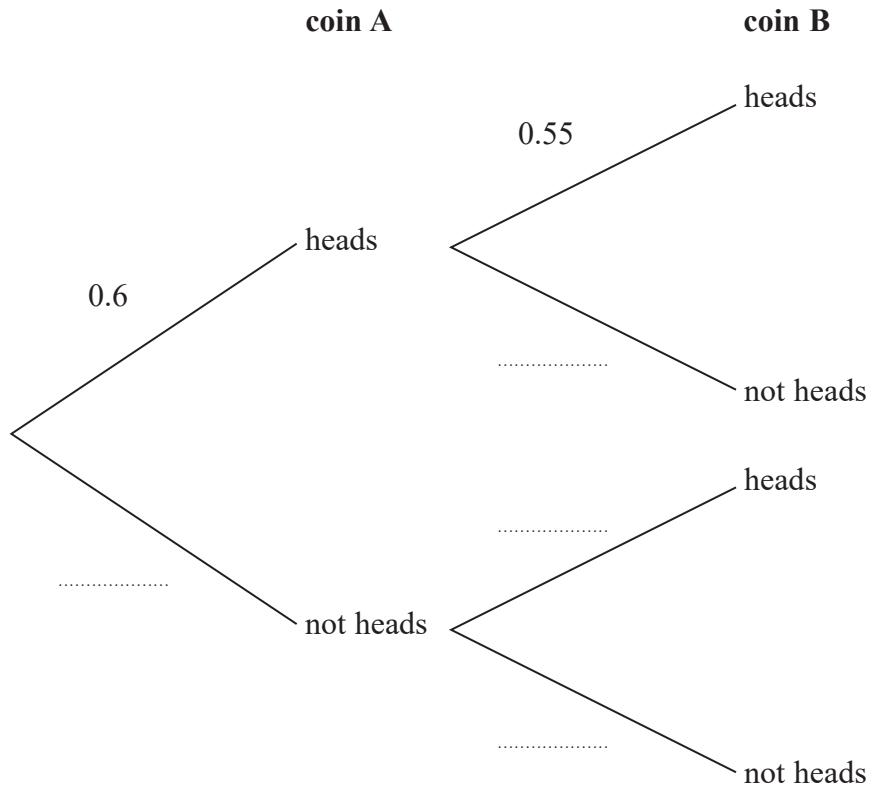

(2)

Tim throws coin A once and he throws coin B once.

(b) Work out the probability that both coins land on heads.

.....  
(2)

(Total for Question 27 is 4 marks)



28 A paddling pool is in the shape of a cylinder.

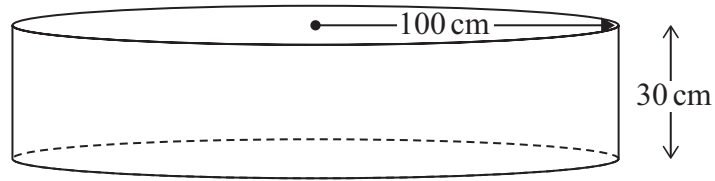

The pool has radius 100 cm.  
The pool has depth 30 cm.

The pool is empty.  
It is then filled with water at a rate of  $250 \text{ cm}^3$  per second.

Work out the number of minutes it takes to fill the pool completely.  
Give your answer correct to the nearest minute.  
You must show all your working.

..... minutes

**(Total for Question 28 is 4 marks)**

DO NOT WRITE IN THIS AREA

DO NOT WRITE IN THIS AREA

DO NOT WRITE IN THIS AREA





DO NOT WRITE IN THIS AREA

DO NOT WRITE IN THIS AREA

DO NOT WRITE IN THIS AREA

29  $w = 40 - t^2$

(a) Calculate the value of  $w$  when  $t = -5$

$w = \dots\dots\dots$   
(2)

$$p = \frac{h - 5}{3}$$

(b) Make  $h$  the subject of the formula.

$\dots\dots\dots$   
(2)

(Total for Question 29 is 4 marks)

---

TOTAL FOR PAPER IS 80 MARKS



DO NOT WRITE IN THIS AREA

DO NOT WRITE IN THIS AREA

DO NOT WRITE IN THIS AREA

**BLANK PAGE**



DO NOT WRITE IN THIS AREA

DO NOT WRITE IN THIS AREA

DO NOT WRITE IN THIS AREA

**BLANK PAGE**



P 7 6 9 2 6 A 0 2 7 2 8

DO NOT WRITE IN THIS AREA

DO NOT WRITE IN THIS AREA

DO NOT WRITE IN THIS AREA

**BLANK PAGE**

